

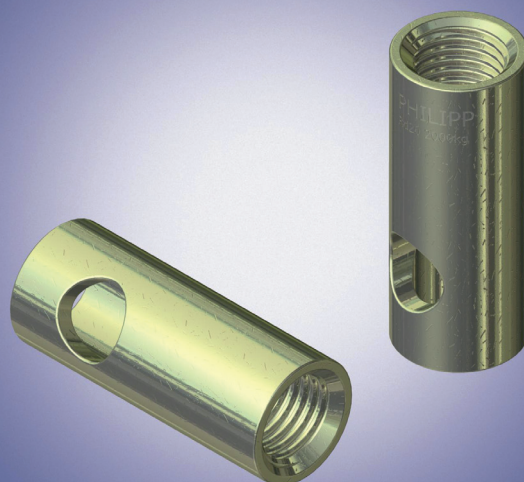

# PHILIPP Lifting Insert with Cross Hole Installation Instruction



# INSTALLATION INSTRUCTIONS OF PHILIPP LIFTING INSERT WITH CROSS HOLE

The **PHILIPP Lifting Insert** is part of the **PHILIPP Transport Anchor System** and complies with the „Safety Rules for Transport Anchors and Systems for Precast Concrete Units“ (German regulation, BGR 106).

On use of **PHILIPP Lifting Insert** attention must be paid to this installation instructions, the using instructions of **PHILIPP Lifting Loop with Threaded End**, **PHILIPP Wirbelstar** and **PHILIPP Lifty** as well as the general part. The anchor may only be used in combination with the mentioned **PHILIPP Lifting Devices**.

**PHILIPP Lifting Insert** are used for transport of precast concrete units. Multiple uses within the transport chain (from production to installation of the unit) are no repeated uses. Repeated use is only allowed if it complies with the German Approval (DIBt, Berlin No. Z-30.3-6 stainless steel).

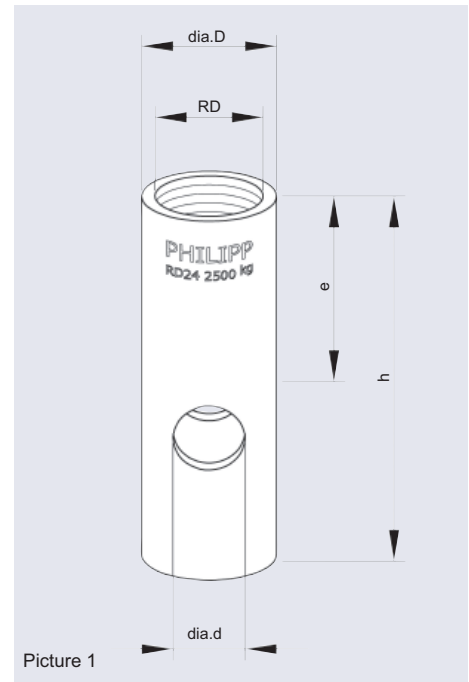

Picture 1

**Table 1: Load Bearing Capacities and Dimensions**

Art.-No. Galvanized	Art.-No. Stainless Steel	Type RD	Load Bearing Capacity [kN]		Dimensions [mm]				Weight [kg/100 pcs.]	PU [pcs.]
			allow. $F_z$ 0°- 45°	allow. $F_Q$ Lateral Tension	dia.D	h	e	dia.d		
71HM12	77HM12VA	12	5.0	2.5	15.0	40	22	8	2.0	200
71HM14	77HM14VA	14	8.0	4.0	18.0	47	25	11	4.0	200
71HM16	77HM16VA	16	12.0	6.0	21.0	54	27	13	6.0	100
71HM18	77HM18VA	18	16.0	8.0	24.0	65	34	13	11.0	100
71HM20	77HM20VA	20	20.0	10.0	27.0	67	35	16	13.0	100
71HM24	77HM24VA	24	25.0	12.5	31.0	77	43	18	18.0	100
71HM30	77HM30VA	30	40.0	20.0	39.5	105	56	23	44.0	50
71HM36	77HM36VA	36	63.0	31.5	47.0	125	68	28	72.0	25
71HM42	77HM42VA	42	80.0	40.0	54.0	145	80	32	110.0	10
71HM52	77HM52VA	52	125.0	62.5	67.0	195	100	40	220.0	5

**For ascertainment of the right load bearing capacity please follow our general installation instruction and technical advice. The weight of 1.0ton results in 10kN.**

On lateral tension the **PHILIPP Lifting Inserts with Cross Hole** have just the half load bearing capacity compared to axial loading. However, this is no limitation because during tilt-up just the half of the unit weight has to be lifted (see also General Installation Instruction).

## 1. Material

The **PHILIPP Lifting Insert with Cross Hole** consists of galvanized precision steel according to DIN50961 in special quality. Alternatively the insert can be delivered in stainless steel whereas the cut surface is protected against corrosion with a special seal. A stirrup is stuck through the hole to transfer the loads into the unit (Picture 2).

## 2. Reinforcement and Back Hanging Stirrup

On use of **PHILIPP Lifting Insert** precast units must be reinforced with a minimum surface reinforcement (Table 2).

 Existing static-structural reinforcement may be taken into account on requested minimum reinforcement according to Table 2.

This minimum reinforcement can be replaced by comparable single reinforcement bars. The concrete must have a minimum strength of **15 N/mm<sup>2</sup>** at first time of lifting. The user is personally responsible for further transmission of load into the unit.

**Table 2: Minimum Surface Reinforcement and Back Hanging Stirrups**

Type	Mesh Reinforcement (quadratic) [mm <sup>2</sup> /m]	Back Hanging Reinforcement			
		dia.d <sub>s</sub> [mm]	d <sub>br</sub> [mm]	L [mm]	Cut Length [mm]
12	131	6	24	240	490
14	131	8	32	280	570
16	131	10	40	330	670
18	188	10	40	420	850
20	188	12	48	440	890
24	188	14	56	480	970
30	188	16	64	650	1320
36	188	20	140	820	1670
42	188	25	175	860	1750
52	188	28	196	1200	2440

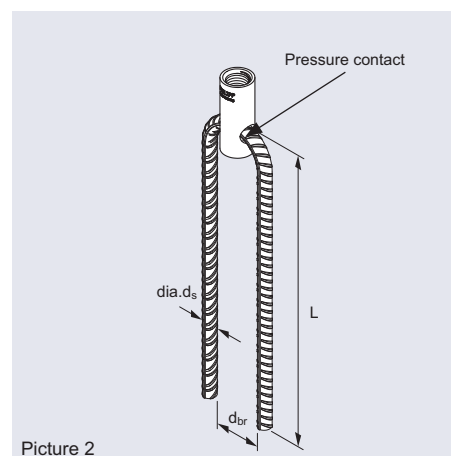

## 3. Center Distance, Edge Distance, Unit Thicknesses

To ensure a safe load transfer the installation and positioning of the **PHILIPP Lifting Inserts** requires minimum dimensions and minimum center distances. The unit thickness **d** covers all load directions (axial, diagonal and lateral loading).

**Table 3: Minimum Center Distance (a<sub>a</sub>), Edge Distance (a<sub>r</sub>), Minimum Thickness of Unit (d)**

Type	a <sub>a</sub> [mm]	a <sub>r</sub> [mm]	d [mm]
12	300	150	60
14	400	200	60
16	400	200	80
18	500	250	100
20	550	275	100
24	600	300	120
30	650	350	140
36	800	400	200
42	1000	500	240
52	1200	600	275

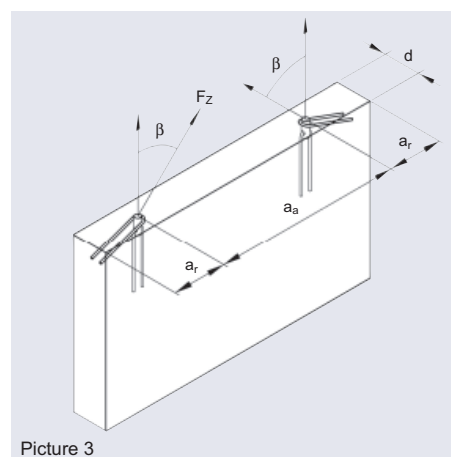

## 4. Additional Reinforcement on Diagonal Tension

The use of **PHILIPP Lifting Insert** under diagonal tension  $\beta \geq 12.5^\circ$  requires additional reinforcement according to Table 4. The diagonal reinforcement is placed contrary to the tensile direction (Picture 3) and has in the summit of the bending pressure contact with the threaded insert (Picture 4a) of the transport anchor. Table 4 gives the user the possibility to use appropriate steel diameter if the inclination is smaller than  $30^\circ$ . Decisive for the choice of the stirrups is the existing diagonal inclination in the transport chain till the mounting of the precast unit.

# INSTALLATION INSTRUCTIONS OF PHILIPP LIFTING INSERT WITH CROSS HOLE

**Table 4: Additional Reinforcement on Diagonal Tension**  
(necessary, if  $\beta \geq 12.5^\circ$ )

Type	at $12.5^\circ \leq \beta \leq 45^\circ$			at $12.5^\circ \leq \beta \leq 30^\circ$		
	dia.d <sub>s</sub> [mm]	L [mm]	d <sub>br</sub> [mm]	dia.d <sub>s</sub> [mm]	L [mm]	d <sub>br</sub> [mm]
12	6	150	24	6	150	24
14	6	200	24	6	200	24
16	8	200	32	6	250	24
18	8	250	32	8	200	32
20	8	300	32	8	250	32
24	10	300	40	8	300	32
30	12	400	48	10	350	40
36	14	550	56	12	450	48
42	16	600	64	14	600	56
52	20	750	140	16	700	67

## 5. Additional Reinforcement for Lateral Loading

If the unit is loaded by a lateral load where the inclination is  $\gamma \geq 15^\circ$ , an additional reinforcement is required (Table 5). The reinforcement for lateral loading is installed in the front side of the wall contrary to the load direction. Pitching the wall can cause diagonal and lateral loading at the same time (Picture 5a and 5b). In this case only the reinforcement for lateral loading is required (anchorage reinforcement tail or double reinforcement tail). The diagonal loading is then already covered.

Turning or tilting up the unit during mounting requires lateral reinforcement (anchorage reinforcement tail according to Picture 6b). The double reinforcement tail (6a) covers all the other loads. At lateral loading the mesh reinforcement (Table 2) must be applied as a mesh cap. Additionally to the mesh cap longitudinal reinforcement must be installed according to Table 5.

Table 5 gives the user the possibility to use an anchorage reinforcement tail (Picture 6b) or a double reinforcement tail (Picture 6a) for lateral loading. Both stirrups must have pressure contact with the tread of the transport anchor. Lateral loading with **PHILIPP Lifting Insert** are only allowed for unit thicknesses **d** according to Table 3.

**Table 5: Additional Reinforcement on Lateral Tension**  
(necessary, if  $\gamma \geq 15^\circ$ )

Type	dia.d <sub>s1</sub>	L	H	d <sub>br</sub>	dia.d <sub>s2</sub>	H <sub>1</sub> *	L <sub>1</sub>	Longitudinal Reinforcement	
	[mm]	[mm]	[mm]	[mm]	[mm]	[mm]	[mm]	[mm]	[mm]
12	6	270	35	24	**	-	-	dia. 10	850
14	6	350	42	24	**	-	-	dia. 10	850
16	8	420	49	32	8	49	600	dia. 10	850
18	8	460	55	32	8	55	750	dia. 12	850
20	10	490	64	40	10	64	800	dia. 12	850
24	12	520	75	48	12	75	800	dia. 12	850
30	12	570	92	48	16	92	1000	dia. 16	1000
36	14	690	118	56	14	118	1000	dia. 16	1000
42*	16	830	143	64	16	149	1200	dia. 16	1000
52*	20	930	174	140	20	174	1500	dia. 20	1200

\* additional reinforcement dia. 14mm, l=60cm (Picture 4b)

\*\* for this unit sizes the minimum unit thickness is too small for a double reinforcement tail

